

OPERATING INSTRUCTIONS

MODEL 800

K-TYPE THERMOMETER

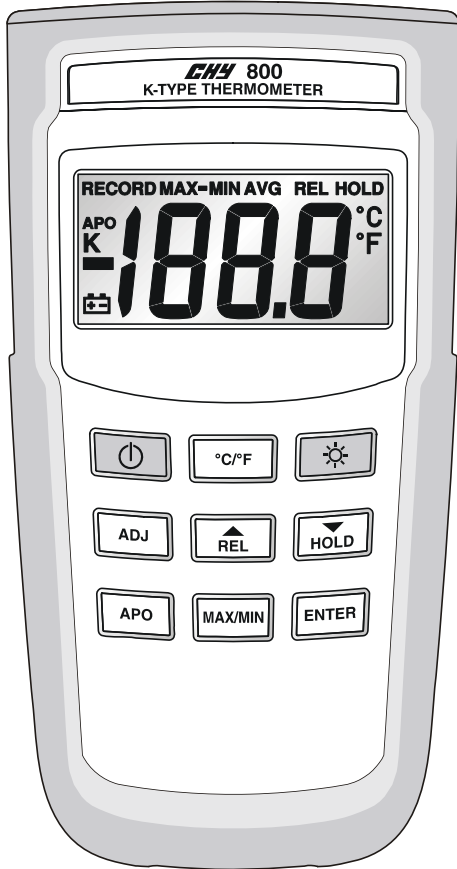

SAFETY INFORMATION

It is recommended that you read the safety and operation instructions before using the thermometer.

WARNING

To avoid electrical shock, do not use this instrument when working voltages at the measurement surface over 24V AC or DC.

WARNING

To avoid damage or burns, do not make temperature measurement in microwave ovens.

CAUTION

Repeated sharp flexing can break the thermocouple leads. To prolong lead life, avoid sharp bends in the leads, especially near the connector.

SPECIFICATIONS

ELECTRICAL

Temperature Scale: Celsius or Fahrenheit user-selectable
Thermocouple Range:

K-TYPE(0.1°C)-200°C to 1372°C, -328°F to 1999°F
Auto range: 0.1°C/1°C, 0.1°F/1°F

Accuracy: Accuracy is specified for operating temperatures over the range of 18°C to 28°C (64°F to 82°F), for 1 year, not including thermocouple error.
 $\pm(0.1\%rdg+1^{\circ}C)$ on -60°C to 1372°C
 $\pm(0.1\%rdg+2^{\circ}C)$ on -60°C to -200°C
 $\pm(0.1\%rdg+2^{\circ}F)$ on -76°F to 1999°F
 $\pm(0.1\%rdg+4^{\circ}F)$ on -76°F to -328°F

ENVIRONMENTAL

Ambient Operating Ranges:

0°C to 50°C (32°F to 122°F) <80% R.H.

Storage Temperature:

-20°C to 60°C (-4°F to 140°F) <70% R.H.

GENERAL

Low battery indication: The  is displayed when the battery voltage drops below the operating level.

Measurement rate: 2.5 times/second.

Operating environment: 0°C to 50°C at <70% R.H.

Storage temperature: -20°C to 60°C, 0 to 80% R.H. with battery removed from meter.

Accuracy: Stated accuracy at 23°C±5°C, <75% R.H.

Battery: 1.5Vx4pcs AAA size.

Battery Life: 200 hours typical with carbon zinc battery.

Dimensions: 160mm(H) x 83mm(W) x 38mm(D).

Weight: Approx. 240g including batteries.

OPERATING INSTRUCTIONS



1. “” Power Button

Press the “” key to turn on or off thermometer. In the MAX/MIN record mode can not power off, must leave MAX/MIN record mode then power off.

2. “°C/°F” Button: Selecting the Temperature Scale

Reading are displayed in either degrees Celsius(°C) or degrees Fahrenheit(°F). When the thermometer is turned on, it is set to the temperature scale that was in use when the thermometer was last turned off. To change the temperature scale, press the “°C/°F” key.

3. “” Button: Display Back-Light

Press the key to turn on the Back-Light. Press the “” key again to make the Back-Light lighter and press “” key once more to cancel the Back-Light function. Back-Light on → lighter → Back-Light off.

4. “ADJ” Button: Adjust thermocouple offset

4.1 Insert the bead wire into a known temperature (T) until the display equal to known temperature (T).
 exp: ice point at 0°C

boiling water at 100°C (Press “ADJ” key).

4.2. Press “▲” or “▼” to add or subtract the value.

4.3. It can be adjusted $\pm 6^{\circ}C$ ($\pm 10.8^{\circ}F$) of default. If you can't adjust your T/C, please check your T/C or send the meter to be calibrated.

4.4. Press “ENTER” key to confirm.

5. “▲/REL” Button

Press “REL” key to enter Relative mode, zero the display, and store the displayed reading as a reference value and annunciator REL is displayed. Pressing “REL” key over 2 seconds to exit the relative mode.

6. “▼/HOLD” Button

Press the “HOLD” key to enter the Data Hold mode, the “HOLD” annunciator is displayed at the higher center of display. When HOLD mode is selected, the thermometer held the present readings and stops all further measurements. Press the “HOLD” key again cancels HOLD mode, causing thermometer to resume taking measurements.

7. “APO” Button

Pressing “APO” key to trigger ON or OFF APO mode, and then APO annunciator will appear or disappear on the display. Power is automatically turn off, if no operation for a period of time, and “APO” annunciator is displayed at upper-left corner when APO function is enabled.

8. “MAX/MIN” Button

Press “MAX/MIN” key to enter the MIN MAX recording mode. (Displays the Maximum reading, Minimum reading, “MAX-MIN”, “AVG” reading stored in record mode). Press “MAX/MIN” key to cycle through the MAX, MIN, MAX-MIN, “AVG” readings. In this mode, press “HOLD” key to stop recording, all values are frozen, press again to restart recording.

In this mode, the APO function and other keys is disabled, excluding “HOLD” and “” keys. To prevent accidental loss of MAX, MIN and MAXMIN, in this mode can only be cancelled by pressing and holding down the “MAX/MIN” key for 2 seconds to exit and erased recorded reading.

MAINTENANCE

WARNING

To avoid possible electrical shock, disconnect the thermocouple connectors from the thermometer before removing the cover.

Installing and Replacing Battery

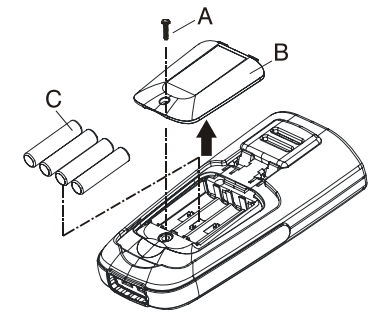

A. Screw

B. Battery Cover

C. Battery

1. Power is supplied by 4pcs 1.5V (SIZE AAA) UM-4 R03.
2. The  appears on the LCD display when replacement is needed. To replace battery remove screw from back of meter and lift off the battery cover.
3. Remove the battery from battery contacts and replace.
4. When not use for long time remove battery.
5. Don't keep in place with high Temp, or high humidity.

Cleaning

Periodically wipe the case with a damp cloth and detergent, do not use abrasives or solvents.